

TENDEZ A LA VICTOIRE



OWNER'S MANUAL
CB14 - CB14 PRO

TENNISPRO DISTRIBUTION

WWW.TENNISPRO.FR



MACHINE FEATURES

- Electric Constant Pull Tensioner w/ 11 lbs. to 89 lbs. Tension Range
- Digital Tension Setting Display
- Professional Six Point "Quick Mount" Racquet Mounting System- Accomodates All Racquets Without Adapters
- Parallel Jaw Rotating Gripper w/ Diamond Dust Coated Gripping Surfaces
- Professional Dual Action, Rotating, Diamond Dust Coated, Fixed String Clamps
- High Strength Extruded Aluminum Frame with Durable Anodized Finish and Convenient Padded Tool Tray
- Unique Internal Drawer System for Storing Tools and Adaptors.
- Convenient Foot Actuated Tensioner Switch (Optional)

ASSEMBLY INSTRUCTIONS

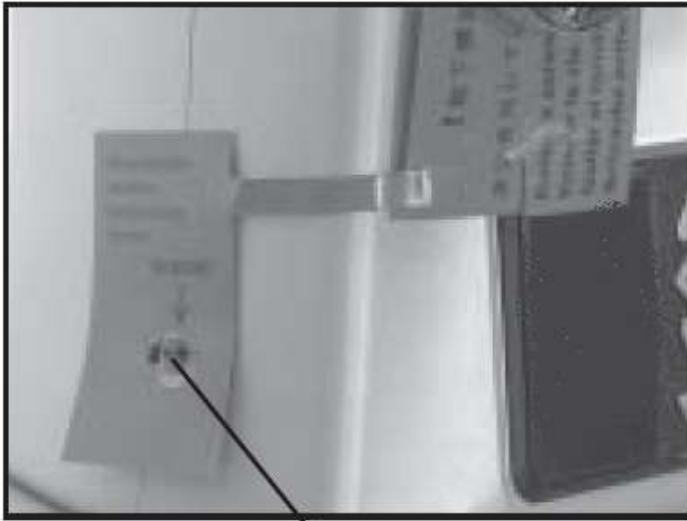

Remove this Screw

Transportation Screw

The machine has been shipped with a motor and load cell protection screw. Remove the screw before using the machine. Retain the screw for future shipment. Install the included rubber grommet into the hole.

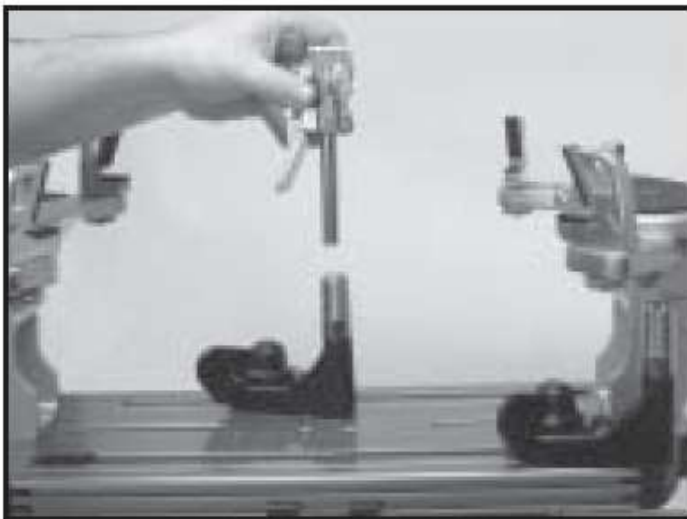

String Clamp Installation

The post of the string clamp and tube of the string clamp base are treated with grease to provide protection against corrosion during shipping. Remove any excessive grease with a clean cloth prior to use. The post and tube may also be cleaned with isopropyl alcohol. After this type of thorough cleaning, the post and tube should be treated with a light coating of machine oil to protect the surfaces against corrosion and to ensure smooth operation.

POWER CONNECTION & CONTROLS

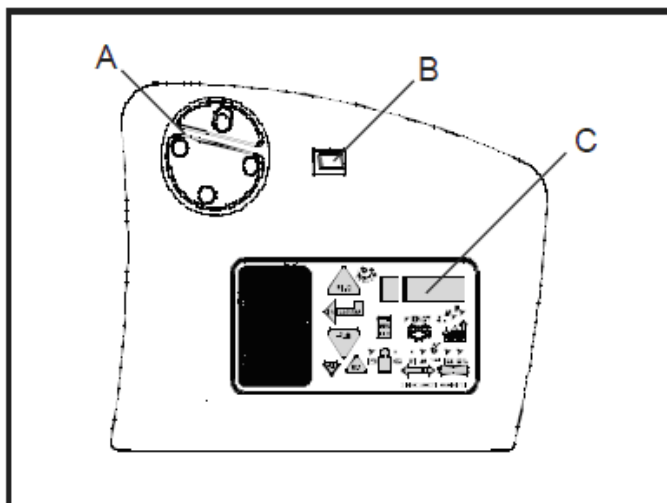

Front Panel Features

- A - String Gripper
- B - Tension Switch
- C - L.E.D. Tension Display

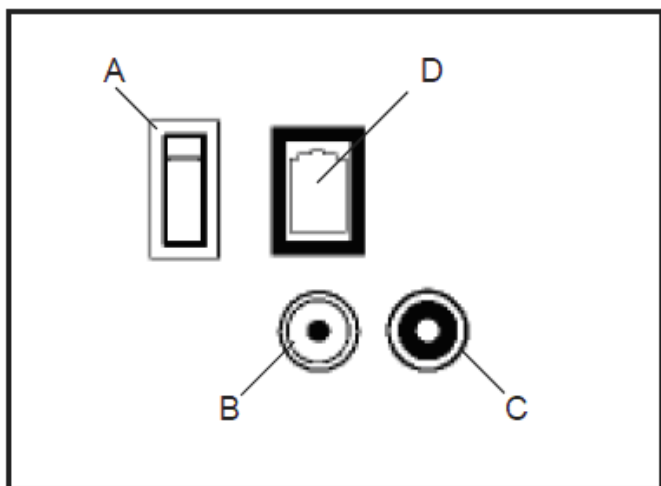

Back Panel Features

- A - Lighted Power Switch
- B - Foot Pedal Switch Receptacle
- C - A/C Power Cord Socket
- D - String Length Meter (currently not available)

Instructions for Power Connection and Controls

CAUTION ! Before connecting to the power supply, check the voltage source that the machine is being connected to. The acceptable range of input voltages for this machine is between 100 V and 240 V @ 50 to 60 Hz. If you have any questions regarding the input voltage supply for your area, please ask your electric utility company.

To install the power cord, insert the female end of the power cord into the AC Adapter and then insert the female end of the cord from the AC Adapter into the A/C Power Cord Socket "C" located on the back panel of the tensioner. Plug the male end of the power cord into a grounded power outlet. When using extension cords, use grounded heavy duty extension cords rated for 15 AMP service.

To connect the foot pedal switch, insert the male pin at the end of the foot pedal switch cord into the Foot Pedal Switch Receptacle "B" located on the back panel of the tensioner.

Switch on the machine by pressing the Lighted On-Off Power Switch on the back panel. At start-up, the LED will display a countdown from "9.0" to "0.0" while the machine performs a self diagnostics check at start-up.

CONTROL PANEL FUNCTIONS AND FEATURES

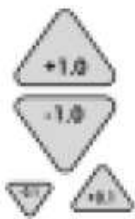
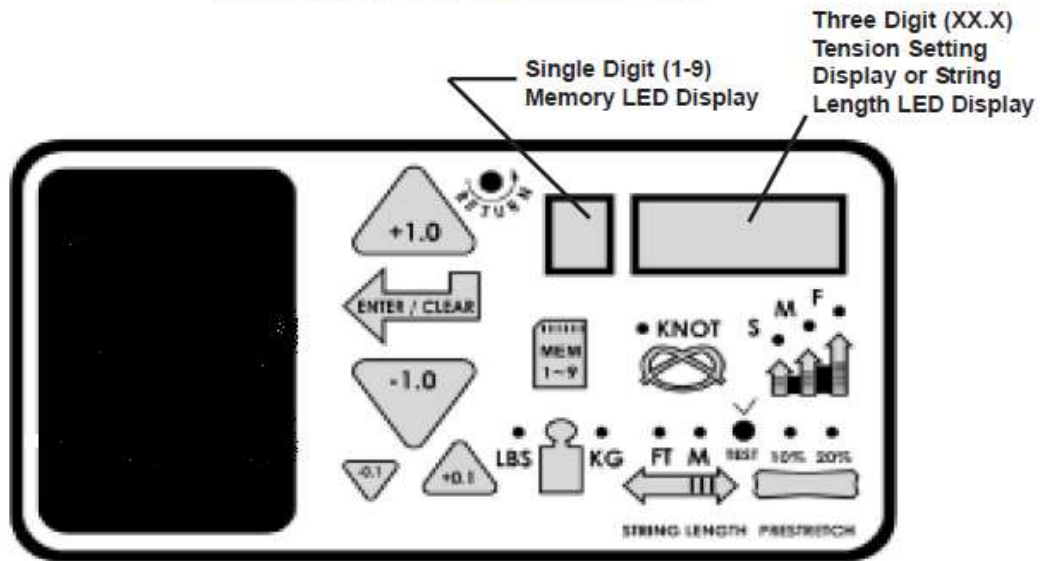

Tension Index Buttons - Changes tension setting in +/- 1.0 or +/- 0.1 Lb or Kg increments. Holding the button down will scroll the tension setting values up or down. Tension settings entered with the tension index buttons are placed into temporary memory setting "0".



Memory Button - Indexes from 9 preset tension settings that can be stored in memory. Settings are retained even if machine is turned off. Each press of the button indexes to the next memory setting. Memory settings 1-9 must be entered using the keypad followed by pressing the "ENT" button.



Clear Button - Clears display to enter a new tension or to reset String Length Meter measurement



Enter Button - Saves displayed tension for Memory setting - when tension is entered using the keypad display flashes until this button is pressed to save the setting. Also Clears display for String Length Meter measurements



Test Button & Racquet Strung - Press once for approximate number of racquets strung. Press again to return. Press and hold for 5 seconds and the machine does an internal diagnostic check, such as the one performed at start-up.



Knot Function - Increases pulling tension by 10% over the setting value (max 90 lbs / 40.8 kgs) for one pull. During the pull the LED stays lit to indicate the Knot function is enabled.



Lbs/Kgs Button - Changes tension display from Lbs to Kgs. Each press of the button toggles back and forth between Lbs and Kgs.

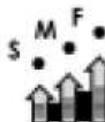

Speed Button - Changes pulling speed of winder from Fast (default) to Medium to Slow. Slow speed is recommended for low stretch strings, such as Kevlar. Each press of the button toggles between Fast, Medium and Slow speeds.

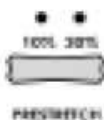

Pre-Stretch Function - Pulls string 10% or 20% over the tension setting (up to 90 lbs / 40.8 kgs), releases the string, and repulls to the tension setting. Each press of the button toggles between 10%, 20% or no pre-stretch.



String Length Meter Button - feature is currently not available.

POWER CONNECTION & CONTROLS

Setting the String Tension

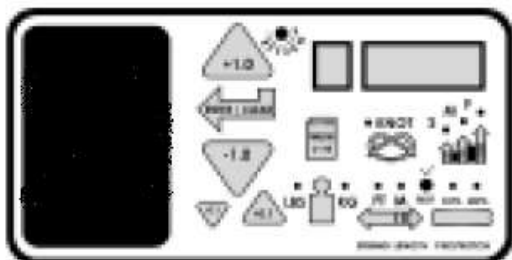

String tensions may be entered and stored into one of nine memory storage settings (See section on Control panel Functions and features) by using the tension index buttons. While tension setting is entered, the value displayed will be temporary until the "Enter" button is pressed to store it in one of the nine permanent memory settings.

Aramid fiber and metallic strings will generally string up tighter on the X-Elis machine compared to synthetic or natural gut strings. Therefore, when stringing with Aramid (Kevlar, Technora) hybrid strings or metallic strings, we recommend setting tension 4-5 lbs. lower than you would normally use for synthetic or natural gut strings.

MOUNTING THE FRAME



Adjusting the Frame Support Posts

Loosen the lock bolts of the frame support posts and space them apart with the frame support slides separated by the approximate length of the racquet head. Although it is not required, it is good practice to center the support posts on the turntable. Lock one of the posts in position by tightening the lock bolt and position the other post until the frame support slide is positioned near the inside surface of the racquet frame. Securely tighten the lock bolt of the second support post.

Caution: To avoid racquet damage, the center posts should not contact the racquet prior to locking down the support posts.



Tightening the Frame Supports

Tighten the Frame Support Slides by turning the adjustment knob clockwise until snug against the racquet frame and slight resistance is felt.

Caution: Overtightening the Center Supports will stretch the head of the racquet and could cause racquet damage.

MOUNTING THE FRAME



Frame Shoulder Support Adjustment

Being sure the shoulder supports are free to swivel in their mountings, simultaneously rotate the shoulder support adjustment knobs clockwise until both shoulder supports gently and squarely contact the frame.



Securing the Frame Shoulder Clamps

Lock the shoulder supports in position by turning the knob at the base clockwise.

Repeat the adjustment procedure for the remaining support post.

Re-tighten all of the frame supports in the same order as before.

Do not overtighten any of the supports as racquet damage may occur.

The supports should be tightened to the point where the racquet frame will not move in the mounting system when the handle is grasped and attempts are made to move it. Should any supports lose contact with the frame while stringing, they should be re-tightened.

STRINGING THE FRAME

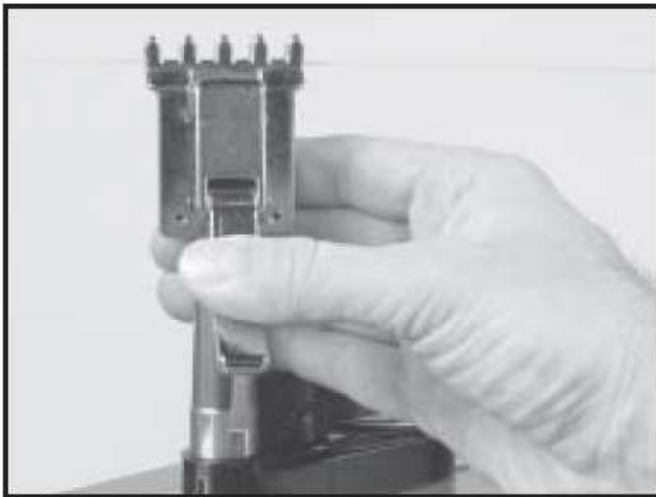

String Clamp Operation

The string clamps are a dual action design where the string clamp and clamp base operate independently of one another.

To clamp a string, lift the clamp head and place the string between the jaws and depress the string clamp lever to secure the string. The clamping pressure applied to the string should be adjusted to provide sufficient pressure to secure the string when subjected to the desired pulling tension. The diamond coated gripper plates provide for

increased friction between the clamps and the string to allow for reduced clamping pressure while securing and holding the string under tension.



Clamp Base Operation

To lock the string clamp base to the turntable, rotate the clamp base locking lever clockwise. To release the string clamp base from the turntable, rotate the clamp base locking lever counter-clockwise.

The Locking Lever should be tightened enough to prevent clamp base slippage on the turntable, when the desired tension is placed on the string. To go from the loose position to the clamped position and back, generally requires the rotation permitted by the slot in the clamp base.



Getting Started

To begin stringing the main strings, thread the two ends of the string through the two center holes at the appropriate end of the frame and continue through the opposite center holes. Thread one end of the string through the adjacent grommet hole and pull excess by hand.

Secure one of the strings using a string clamp.

STRINGING THE FRAME

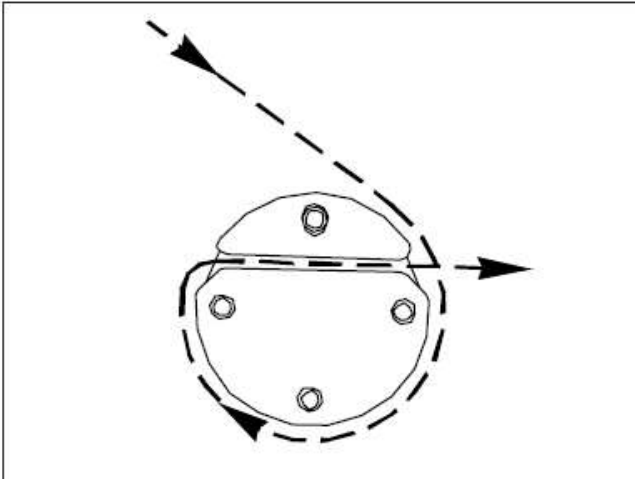

Pulling Tension

To pull tension, wrap the free string clockwise around the gripper drum and position the string between the gripper jaws.

The string must pass over the top half of the gripper before being placed between the gripper jaws, as the tension on the string provides the clamping force to the gripper jaws.

Gently pull the string until all slack is removed.

WARNING: KEEP FINGERS AWAY FROM GRIPPER DRUM WHILE TENSIONING STRING. PUSH GRIPPER REVERSING SWITCH IN CASE OF EMERGENCY.



To tension a string, push the tension switch or the foot pedal. The string gripper will rotate and slowly apply tension to the string. When the set tension has been attained, the gripper will stop rotating. As the tensioned string stretches, the gripper may rotate intermittently, maintaining the set tension.

To release the string after clamping, push the tension switch or foot pedal. If the string gripper does not release the string, depress and hold the Gripper Reversing Switch once to release the string.



Clamping the First Main String

Secure the tensioned main string using the remaining fixed clamp. Repeat the procedure for all of the remaining main strings and tie off following the racket manufacturer's recommendations.

Follow the manufacturer's recommended stringing pattern for one or two piece stringing. This will determine the starting point for the cross strings. If applicable, tie the first cross string using an appropriate starting knot.

STRINGING THE FRAME



Weaving the Cross Strings

Weave the cross strings over and under the main strings being careful to alternate the weave direction of each consecutive cross string so as to be opposite of the previously installed cross string.



Completing the String Job

Once the final cross string is tensioned and clamped, tie off at the appropriate hole specified by the racquet manufacturer. Remove the frame from the mounting system by loosening the shoulder supports and frame supports.

ADDITIONAL FEATURES



Turntable Brake

The turntable may be locked in any position. Rotate the lever to the right to lock the turntable and to the left to release the turntable.

PATHFINDER AWL



The machine includes the Pathfinder stringing awl which creates a pathway between or around strings to make inserting a string through tight grommets easier and quicker.

Insert the awl through the grommet hole in the same manner as for traditional awls. The Pathfinder awl must be in the closed position before insertion.



Once the awl is inserted, pull the handle of the awl outward while holding the tip section in place, leaving the outer sheath in the grommet hole.

Insert the end of the string into the center of the sheath.

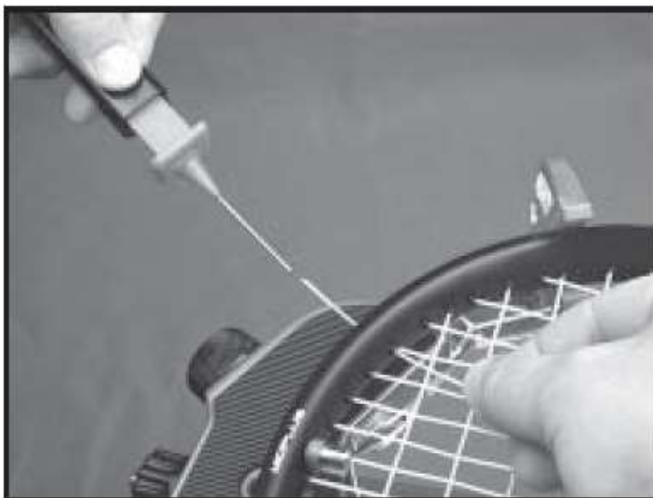

While holding pressure on the string, slowly pull the sheath out of the grommet hole to leave the end of the string exposed.

MAINTENANCE & ADJUSTMENTS

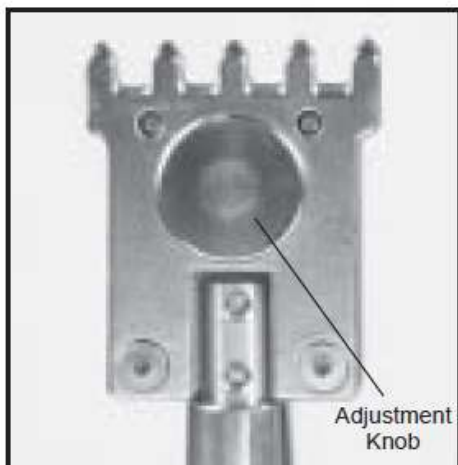

Adjusting the String Clamp Jaw Spacing

The string clamps will need minor adjustments according to what string type, construction, and gauge you are using.

To adjust the gap (clamping pressure) between the clamp jaws, insert the string through the racquet as if you were beginning the main strings. Clamp the strings and pull tension. If the string slips through the jaws of the clamp, tighten the clamp by compressing the clamp jaws together by hand while turning the Adjustment Knob, in the clockwise direction. If the clamp leaves impressions or damages the string, it may be excessively tight and should be adjusted by turning the Adjustment Knob

counter clockwise to open the gap between the jaws. The clamp jaws should be cleaned periodically to be free from dirt, oil, and any string coating for them to grip properly. Knife sharpening stones are excellent for removing build-up on the diamond coated surfaces and are available.

Note: The string clamps supplied with your stringing machine can accommodate tight string patterns such as badminton. Depending on the string pattern, the clamp may spread the strings slightly which will not compromise the quality of the string job. String clamps designed specifically for badminton racquets are available.



Clamp Base Locking Nut Adjustment

In the event the Locking Lever rotation is insufficient to ensure smooth operation of the clamp base, very minor adjustments to the Clamp Base Locking Nut can be made with the supplied 17mm socket. Tighten or loosen the locking nut in very small increments to provide more clamping pressure or running clearance as needed.



Quick Action Clamp Base Removal

Quick Action clamp bases can be removed from the turntable for maintenance or cleaning by removing clamp stop located at the end of the slot in the turntable. To remove the clamp stop, remove the two screws holding the clamp stop in place from the underside of the turntable. Lift the clamp stop out of the slot, slide the clamp base to the end of the slot and lift it out. Replace the clamp base and clamp stop in reverse order.

TROUBLESHOOTING TIPS

| <u>PROBLEM</u> | <u>SOLUTION</u> |
|---------------------------------------|--|
| String slips in clamps | <ul style="list-style-type: none">- Adjust gap between clamp jaws- Clean clamp jaws |
| String slips in gripper | <ul style="list-style-type: none">- Clean gripper jaws- Make sure string is wrapped over top jaw of gripper prior to inserting between gripper jaws |
| String clamp base slips on turntable | <ul style="list-style-type: none">- Clean bottom of clamp & glide bar with alcohol- Adjust clamp base locking nut |
| Electrical system does not function | <ul style="list-style-type: none">- Check power source- Check power cord connection |
| String tension too tight or too loose | <ul style="list-style-type: none">- Check tension using a tension calibrator, adjust machine calibration if necessary |

TENNISPRO.FR
B.P. 40153
67603 SELESTAT CEDEX FRANCE
Tél. :03. 88.92.09.09 – Fax : 03. 88 92 82 17